

MV "PAIMPOL"

FACT SHEET

MV PAIMPOL: CALL SIGN: V2EA4 - IMO NO 9144457

T/C OWNERS: K/S COMBI LIFT - 4220 KORSOER - DENMARK
 PORT OF REGISTRY: ST. JOHNS
 FLAG: ANTIGUA



MAIN PARTICULARS :

CLASS:

GL + 100 A5 E RO-RO – LO-LO MULTIPURPOSE CARRIER –
 STRENGTHENED FOR HEAVY CARGO - EQUIPPED FOR CARRIAGE
 OF CONTAINERS AND DANGEROUS GOODS – SOLAS II-2, REG.
 54/MC E AUT.

BUILDERS:

PEENE – WERFT, WOLGAST / YARD NO. 476 BUILT 1996

REGISTER TONNAGE:

TYPE	INTERNATIONAL
GROSS	5800
NET	2390

DIMENSIONS:

LENGTH OVER ALL	100,90 M
LENGTH BETWEEN PP	94,60 M
BREADTH MOULDED	18,90 M
DESIGN DRAFT MOULDED	6,62 M
DEPTH TO MAINDECK MOULDED	9,70 M

DEAD WEIGHT CAPACITIES:

DEAD WEIGHT A.T.	5.100 MTS
------------------	-----------

CONTAINER CAPACITIES:

TOTAL CAPACITY 20' x 8' x 8'6"	501
HEREOF: IN CARGO HOLD	210
ON DECK	291
CAPACITY WITH AVERAGE 14 TS	226
REEFER CONTAINERS	40

STACKLOAD:

TANKTOP	96 TS EACH 20'	125 TS EACH 40'
TWEENDECK	50 TS EACH 20'	65 TS EACH 40'
MAINDECK	50 TS EACH 20'	65 TS EACH 40'

CARGO HOLD:

BOXED - STEEL FLOORING

HATCHES:

1 HATCH WEATHERDECK	70,20 M X 15,60 M
1 HATCH TWEENDECK	37,88 M X 14,85 M

CUBIC CAPACITIES IN HOLDS:

WITH TWEEN-DECK HATCH COVERS	9.720 CBM
------------------------------	-----------

CRANES:

2 ELECTRO HYDRAULIC CRANES PORT SIDE 100 TS / 18 M &
 60 TS / 28 M COMBINABLE UP TO 200 TS

DECK STRENGTH:

TANKTOP - STEEL	10,0 TS PER M2
TWEEN DECK - STEEL PONTOONS	8,0 TS PER M2
MAIN DECK - STEEL PONTOONS	2,2 TS PER M2

TANK CAPACITIES:

FUELOIL	ABT. 465 TS
FRESH WATER	47 TS
BALLAST WATER	1900 TS

ENGINES:

MAIN ENGINE:	1 MAN B&W 12V 32/40
AUX. ENGINES:	2 VOLVO TAMD 162 KC

ALL PARTICULARS BELIEVED TO BE CORRECT, BUT NOT GUARANTEED

TANK TOP

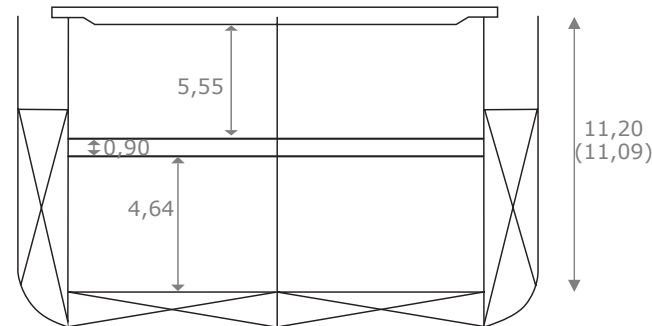
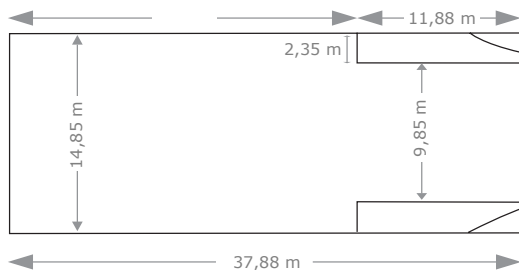

TWEEN DECK

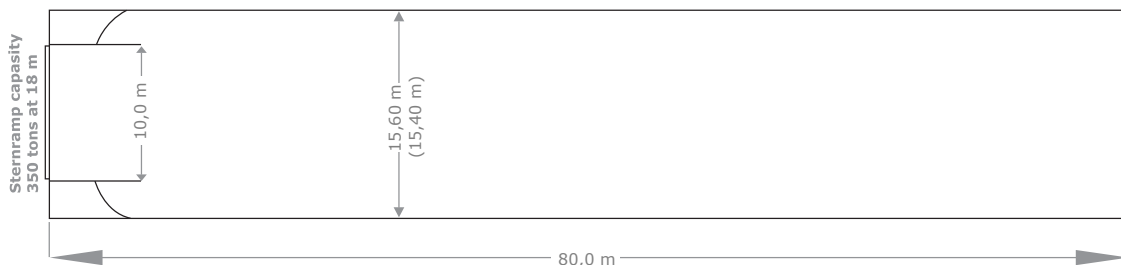

WEATHER DECK

