

MS "MARSUS" FACT SHEET

CALLSIGN: OWJQ2 - IMO 8520434 - SAT C NO 421949010 - GSM 23618266
 EMAIL: MARSUS@SKYFILE.COM
 OWNERS: PARTOWNERSHIP MARSUS C/O J. POULSEN SHIPPING A/S - BATTERIVEJ 7 - KORSØR - DENMARK
 PORT OF REGISTRY: MARSTAL
 FLAG: DANISH



MAIN PARTICULARS :

CLASS:

BUREAU VERITAS I 3/3 E, CARGO SHIP, DEEP SEE, ICE III

BUILDERS:

NORDSØVÆRF TET A/S, RINGKØBING 9/1986

REGISTER TONNAGE:

TYPE	INTERNATIONAL	SUEZ	PANAMA
GROSS	1091	1082,23	
NET	442	880,05	

DIMENSIONS:

LENGTH OVER ALL	67,90 M
LENGTH BETWEEN PP	64,45 M
BREADTH MOULDED	10,00 M
DEPTH TO MAIN DECK	5,90 M
DEPTH TO TWEEN DECK	2,9 M
DRAFT FULLY LOADED SUMMER	11,3

CONTAINER CAPACITIES:

TOTAL CAPACITY 20' x 8' x 8'6"	51
HEREOF: IN CARGO HOLD	33
ON DECK	18
REEFER CONTAINERS	8

STACKLOAD:

TANKTOP	40 MT EACH 20'
DECK	20 MT EACH 20'

CARGO HOLDS:

FITTED AND CERTIFIED FOR IMO 1 CARGO
 WOODEN FLOORING
 30 AIR CHANGES PER HOUR BASIS EMPTY HOLDS
 FITTED WITH SMOKE DETECTORS AND CO₂
 HOLDS CAN BE DIVIDED INTO 8 SEPARATE COMPARTMENTS

CUBIC CAPACITIES IN HOLDS:

	CBTS . GRAIN	CBFT . BALE
LOWER HOLD 1	18.045	14.866
LOWER HOLD 2	18.186	15.008
UPPER HOLD1	17.621	16.350
UPPER HOLD 2	22.036	20.587

TOTAL HOLD 1	35.666	31.316
TOTAL HOLD 2	40.222	35.596
TOTAL	75.888	66.812

VESSEL HAS 2 SEP LOCKERS OF 2300 AND 1800 CNFT RESP.

WINCHES / DERRICKS:

2 DERRICKS - CAPACITY 8 MT EACH

DECK STRENGTH:

TANKTOP - HARDWOOD	5,6 MT PER M ²
TWEEN DECK - STEEL	2,4 MT PER M ²
MAIN DECK - MACGREGRO STEEL	1,3 MT PER M ²

SPEED AND CONSUMPTION:

10,0 KNOTS ON BT 2,8 MT GO INCL. SHAFTGEN.
 NO GASOIL AT SEA
 IN PORT IDLE 0,5 MT
 IN PORT WORKING WITH WINCHES 1,0 MT

TANK CAPACITIES:

FUELOIL	144 TS
FRESH WATER	20 TS
BALLAST WATER	438 TS

ENGINES:

MAIN ENGINE: ALPHA DIESEL 5L23/30 KVø 850 HP
 AUX. ENGINES: 2 DEUTZ F5L 413 FR OF 92 HP
 1 DEUTZ OF 43 HP
 SHAFTGEN.: 1 OF 125 KVA

BRIDGE EQUIPMENT:

2 RADARS FURUNO
 1 DIRECTION FINDER
 SAT. NAVIGATOR
 800 WATT SHORT WAVE RADIO TRP SP - 2 VHF

ALL PARTICULARS BELIEVED TO BE CORRECT, BUT NOT GUARANTEED

MAIN DECK

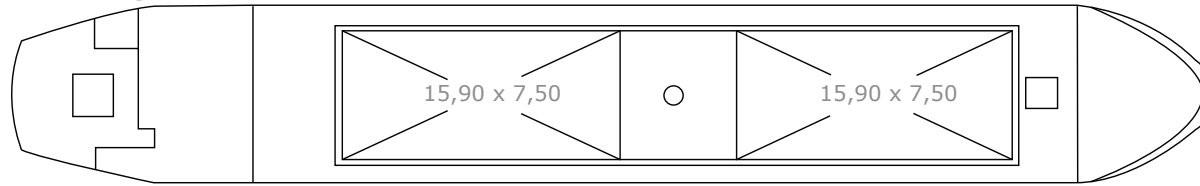

TWEEN DECK

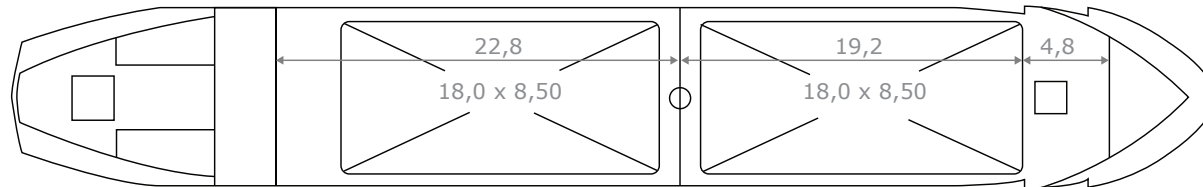

TANK TOP

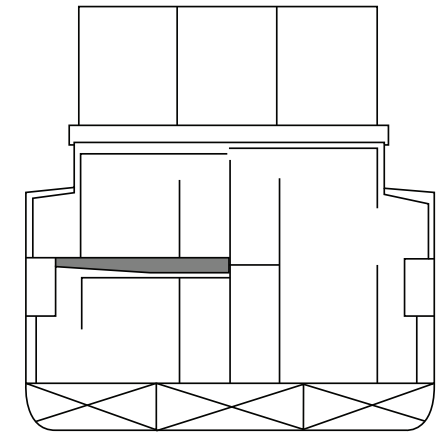
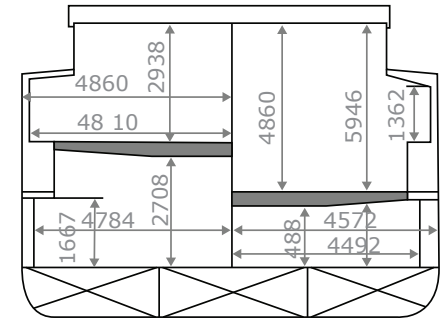
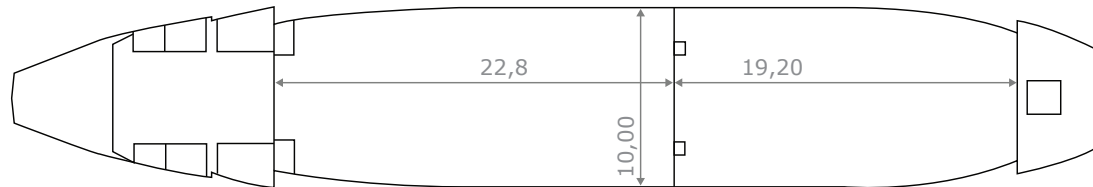

MS "MARSUS"