

FACT SHEET

MS "STAR BIRD"

CALLSIGN: OZEF6 - IMO 9041423 - SAT C NO 421957510 - TEL. 764646198
 FAX. 764646210 - GSM + 45 29678504 - EMAIL: STARBIRD@SKYFILE.COM
 OWNERS: PARTOWNERSHIP STAR BIRD, BATTERIVEJ 7, KORSØR, DENMARK
 PORT OF REGISTRY: KORSØR
 FLAG: DANISH



MAIN PARTICULARS :

CLASS:

GL 100A5 EQUIPPED FOR CARRIAGE OF CONTAINERS
 GL MCE AUT STRENGTHENED FOR HEAVY CARGO

BUILDERS:

MARMARA SHIPYARD, ISTANBUL 9/1993

REGISTER TONNAGE:

TYPE	INTERNATIONAL	SUEZ	PANAMA
GROSS	3351	3320	
NET	1835	2686	

DIMENSIONS:

LENGTH OVER ALL	94,40 M
LENGTH BETWEEN PP	87,10 M
BREADTH MOULDED	15,82 M
DEPTH TO MAIN DECK	7,90 M
DEPTH TO TWEEN DECK	5M
DRAFT FULLY LOADED SUMMER FURTHER	10,6

DEAD WEIGHT CAPACITIES:

DEAD WEIGHT A.T.	5180 MT
DEAD WEIGHT C.C. EST. I	4920 MT

CONTAINER CAPACITIES:

TOTAL CAPACITY 20' x 8' x 8'6"	351
HEREOF: IN CARGO HOLD	131
ON DECK	220
CAPACITY WITH AVERAGE 14 TS	234
CAPACITY WITH AVERAGE 18 TS	190
REEFER CONTAINERS	50

STACKLOAD:

TANK	72 TS EACH 20' 90 TS EACH 40'
DECK	30 TS EACH 20' 40 TS EACH 40'

CARGO HOLDS/HATCH:

1 HATCH	55,80 X 12,94 M
1 HOLD	58,00 X 12,94 M
BOXED - STEEL FLOORING	
30 AIR CHANGES PER HOUR BASIS EMPTY HOLDS	

FITTED WITH SMOKE DETECTORS AND CO₂
 HOLDS CAN BE DIVIDED INTO 4 SEPARATE COMPARTMENTS

CUBIC CAPACITIES IN HOLDS:

BALE	211.500 CBFT
------	--------------

CRANES:

2 EL HYDRALIC KGW-CRANES MOUNTED PORT SIDE EACH
 60 MT COMBINABLE UP TO 120 TS WITH LIFTING BEAM 110 TS.

DECK STRENGTH:

TANKTOP - HARDWOOD	10,0 TS PER M ²
TWEEN DECK - STEEL PONTOONS	1,96 TS PER M ²
MAIN DECK - STEEL PONTOONS	1,5 MT PER M ²

SPEED AND CONSUMPTION:

SERVICE SPEED ABT 13,0 KNOTS
 12,0 KNOTS ON ABT 7,0 TS IFO 180 INCL SHAFTGEN
 13,0 KNOTS ON ABT 8,0 TS IFO 180 INCL SHAFTGEN
 13,5 KNOTS ON ABT 8,8 TS IFO 180 INCL SHAFTGEN
 NO GASOIL AT SEA
 IN PORT IDLE 0,8 TS

TANK CAPACITIES:

FUELOIL	280 TS
GASOIL	70 TS
FRESH WATER	70 TS
BALLAST WATER	1820 TS

ENGINES:

MAIN ENGINE:	MAK TYPE 6M 453C WITH 2200 KW
AUX. ENGINES:	3 MTU OF 313 KW/1 MTU OF 87 KW
SHAFTGEN.:	1 OF 325 KW
BOWTRUSTER	1 OF 200 KW

BRIDGE EQUIPMENT:

LOADMASTER
 2 RADARS RACAL DECCA BRIDGEMASTER
 DOPPLER LOG
 GMDSS EQUIPPED A1 + A2 + A3

ALL PARTICULARS BELIEVED TO BE CORRECT, BUT NOT GUARANTEED

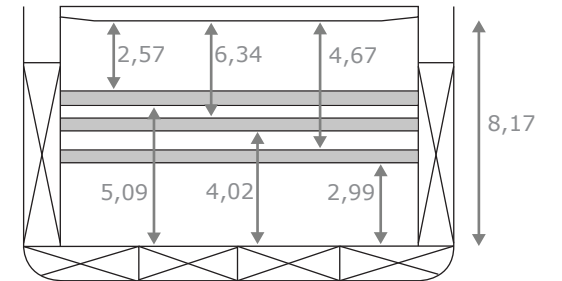
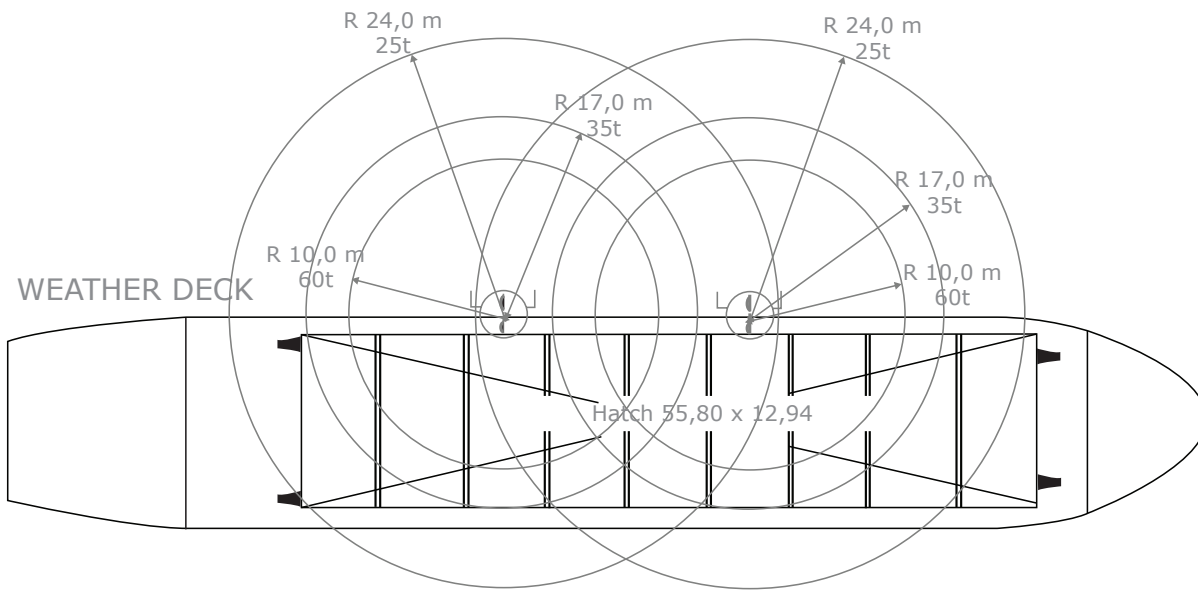

TWEEN DECK

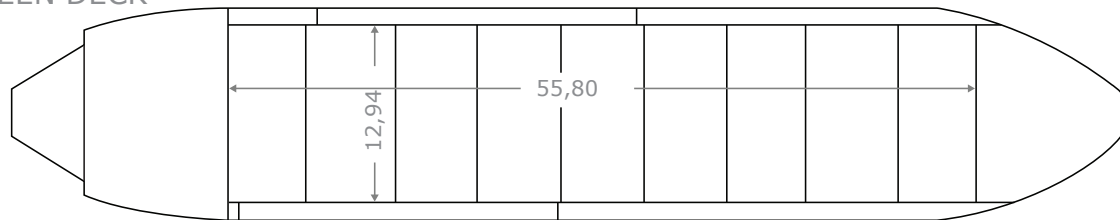

TANK TOP

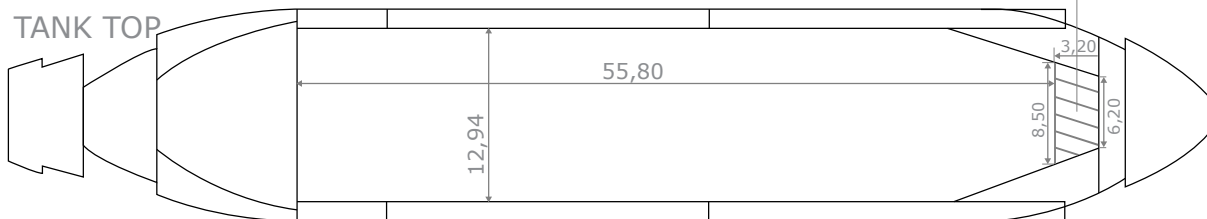

COMPARTMENT 3,20 M LONG X 8,50 M WIDE
 NARROWING TO 6,20 M.
 MAX HEIGHT IN COMPARTMENT= 2,99 M